

PHASE CONTROL OF ENTANGLED STATES

J. C. Gonzalez-Henao

Instituto de Física "Gleb Wataghin"
Universidade Estadual de Campinas
Unicamp, Campinas, São Paulo, Brazil
juliocg@ifi.unicamp.br

E. Pugliese

Istituto Nazionale di Ottica
Consiglio Nazionale delle Ricerche
Largo E. Fermi 6, Firenze, Italy
eugenio.pugliese@ino.it

S. Euzzor

Istituto Nazionale di Ottica
Consiglio Nazionale delle Ricerche
Largo E. Fermi 6, 50125 Firenze, Italy
stefano.euzzor@ino.it

Dipartimento di Scienze della Terra
Università degli Studi di Firenze
Via G. La Pira 4, Firenze, Italy
eugenio.pugliese@unifi.it

S. F. Abdalah

Istituto Nazionale di Ottica
Consiglio Nazionale delle Ricerche
Largo E. Fermi 6, 50125 Firenze, Italy
sora.abdalah@ino.it

R. Meucci

Istituto Nazionale di Ottica
Consiglio Nazionale delle Ricerche
Largo E. Fermi 6, 50125 Firenze, Italy
riccardo.meucci@ino.it

J. A. Roversi

Instituto de Física "Gleb Wataghin"
Universidade Estadual de Campinas
Unicamp, Campinas, São Paulo, Brazil
roversi@ifi.unicamp.br

Abstract

Entanglement is a fundamental quantum feature which plays an important role in quantum information and quantum computing. In recent years, many efforts have been done for understanding the survival of quantum entanglement in open systems at high temperature. In this work, we consider a quantum system of two coupled parametric oscillators in contact with a common heat bath and with a time dependent coupling term. We demonstrate that the oscillators become entangled exactly in the region where the classical counterpart, a Mathieu oscillator, is unstable. The instability regions of the system have been theoretically and experimentally explored by means of a weak sinusoidal perturbation, with adjustable amplitude and phase, applied to the oscillation frequency. We show that if the classical system passes from stable to unstable regions as a consequence of the perturbation, the quantum oscillators become entangled. This means that it is possible to generate and manipulate entanglement controlling the dynamical behaviour of the associated classical system.

Key words

Entanglement, Mathieu Oscillator, Phase Control

1 Introduction

Entanglement is an important resource for several quantum information applications, for example, quantum cryptography, quantum metrology

and quantum computation [Nielsen, Chuang and Grover, 2002][Horodecki, Horodecki, Horodecki and Horodecki, 2009]. However, interactions with the environment, even when very weak, imply decoherence in the system with consequent loss of entanglement [Galve, Pachón and Zueco, 2010]. In this paper we consider a system of two coupled oscillators in contact with a common heat bath and with a time dependent oscillation frequency. The possibility to control the entanglement between the two oscillators has been explored. This is achieved by means of an external sinusoidal perturbation applied to the oscillation frequency. We demonstrate that the oscillators are entangled exactly in the region where the classical counterpart is unstable, otherwise entanglement is not possible. An analog electronic version of the oscillator has been implemented.

2 Theory

As introduced we are considering a system of two coupled oscillators, 1 and 2, interacting with a common heat bath. The underlying Hamiltonian is given by

$$H = \frac{P_1^2}{2m_0} + \frac{m_0\omega^2(t)X_1^2}{2} + \frac{P_2^2}{2m_0} + \frac{m_0\omega^2(t)X_2^2}{2} + c(t)X_1X_2 + \sum_{k=1}^{\infty} \left\{ \frac{p_k^2}{2m_k} + \frac{m_k\omega_k^2 x_k^2}{2} - \sqrt{2}c_k x_k (X_1 + X_2) + \frac{c_k^2}{2m_k\omega_k^2} (X_1 + X_2)^2 \right\}, \quad (1)$$

where $\omega(t)$ is the oscillator frequency of interest and $\{X_1, X_2, P_1, P_2\}$ are the position and momentum op-

erators for 1 and 2; ω_k and $\{x_k, p_k\}$ are the frequencies and the position and momentum operators of the environment oscillators; the constants c_k correspond to coupling coefficients between the oscillators 1 – 2 and the environment and $c(t)$ is the coupling between the oscillators. After some operator transformations the above Hamiltonian can be rewritten as:

$$H = H_+ + H_- \quad (2)$$

$$H_- = \frac{P_-^2}{2m_0} + \frac{m_0\Omega_-^2(t)}{2} X_-^2 \quad (3)$$

$$H_+ = \frac{P_+^2}{2m_0} + \frac{m_0\Omega_+^2(t)}{2} X_+^2 + \sum_{k=1}^{\infty} \frac{p_k^2}{2m_k} + \frac{m_k\omega_k^2}{2} \left(x_k - \frac{\sqrt{2}c_k}{2\omega_k^2} X_+ \right)^2 \quad (4)$$

where $\Omega_{\pm}^2(t) = \omega^2(t) \pm c(t)/m_0$, H_- and H_+ are the Hamiltonian of a free oscillator and an oscillator coupled with the environment, respectively.

The connection between classical instabilities and the existence of quantum entanglement relies on the evaluation of the covariance matrix elements of the operators $\{X_1, X_2, P_1, P_2\}$. Such elements depend on the solutions of the following differential equations

$$\ddot{\mathbb{X}}_-(t) + \Omega_-^2(t) \mathbb{X}_-(t) = 0 \quad (5)$$

$$\ddot{\mathbb{X}}_+(t) + \left(\Omega_+^2(t) - \frac{\gamma^2}{4} \right) \mathbb{X}_+(t) = 0, \quad (6)$$

where γ is the damping rate. Equations (5) and (6) are the classical counterparts of the Hamiltonians H_- and H_+ , respectively. These equations have the same structure of a Mathieu equation.

As a measure of entanglement we consider the logarithmic negativity E_N computed from the covariance matrix elements of the operators $\{X_+, X_-, P_+, P_-\}$. As demonstrated in Refs. [Roque and Roversi, 2013] [Gonzalez-Henao, Pugliese, Euzzor, Abdalah, Meucci and Roversi, 2015] the entanglement between the two oscillators only depends on the instability of the solutions of \mathbb{X}_- .

3 Experiment

Here we describe the experimental implementation of a Mathieu oscillator and its control based on the phase control technique. Such an oscillator can be described by the following set of first order differential equations

$$\begin{aligned} \dot{x} &= y \\ \dot{y} &= - \left[\omega_o^2 - \frac{\gamma^2}{4} + \varepsilon \cos(\omega_d t) \right] x \\ &= - \left[\omega_r^2 + \varepsilon \cos(\omega_d t) \right] x \end{aligned} \quad (7)$$

where ω_d is the angular driving frequency and the

$\omega_r = \left(\omega_o^2 - \frac{\gamma^2}{4} \right)^{\frac{1}{2}}$ is the natural angular frequency.

It is well known that the parametric oscillator (7) presents diverging solutions when $f_d = \frac{\omega_d}{2\pi}$ approaches some specific values, in particular, around twice the natural frequency $f_r = \frac{\omega_r}{2\pi}$. As we are interested in driving the system to escape from or to enter in these instability regions an analog electronic version of the Mathieu oscillator has been implemented as in Fig.1.

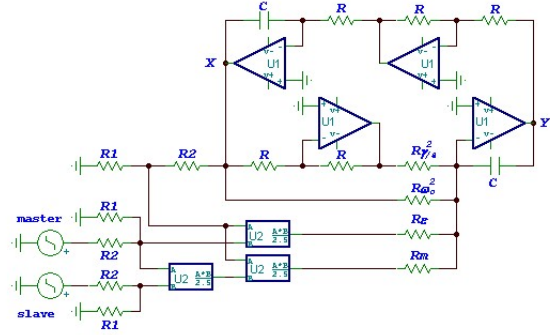

Figure 1. Circuitual implementation of Mathieu oscillator and its phase control. $U_1 = LT1114CN$, $U_2 = MLT04G$, $R_{\gamma^2/4} = 438k\Omega$, $R_{\omega_o^2} = 39k\Omega$, $R_{\varepsilon} = 51k\Omega$, $R_m = 4.7k\Omega$, $R = 43k\Omega$, $R_1 = 1.6k\Omega$, $R_2 = 4.7k\Omega$, $C = 1.45nF$.

The circuit is realized using commercial electronic components. The harmonic oscillator with natural frequency f_r , is obtained by using a cascade of four operational amplifiers LT1114CN by Linear Technology. A function generator Hameg HM 8131-2 provides the sinusoidal driving signal $V_{\varepsilon} = \varepsilon \cdot \cos(\omega_d t)$, a multiplier chip MLT04G by Analog Devices is used to implement the product $V_{\varepsilon} \cdot x$. The experimental evidence of diverging solutions (X and Y outputs in Fig.1) is given by observing saturation imposed by the integrated electronic components. By varying f_d , the system approaches the instability region and the oscillating solutions become modulated at the frequency difference $f_d - f_r$. The modulated signal will be clipped when saturation is reached. Inside the instability region the signal exceeds the saturation threshold value and the amplitude modulation vanishes.

The regions of instability, resembling the Arnold's tongues of the circle map, have been experimentally reconstructed in the parameter space $\varepsilon - f_d/f_r$ (see Fig.2). In order to handle dimensionless quantities, the variable ε has been rescaled to the amplitude of the harmonic oscillator. The first two instability regions corresponding to $f_d \simeq f_r$ and $f_d \simeq 2f_r$ are reported.

The dynamics of the Mathieu oscillator can be controlled by using the phase control technique. This strategy has been frequently used to tame chaotic behaviour in driven non-linear oscillators. It consists in applying

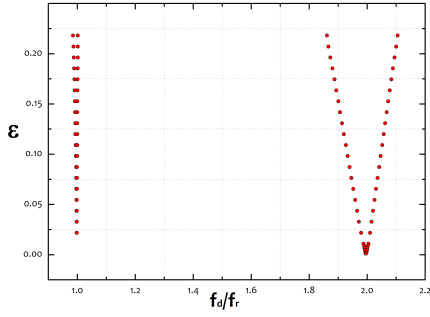

Figure 2. First two instability regions experimentally obtained for several values of ε and f_d of the V_ε signal.

a suitable sinusoidal modulation to a given system parameter. The amplitude of the control signal and the phase difference between the intrinsic oscillation and the sinusoidal control signal are crucial to manipulate the dynamics is modified according to

$$\begin{aligned} \dot{x} &= y \\ \dot{y} &= -\{\omega_r^2 + \varepsilon [1 + m \cdot \cos(\omega_d t + \phi)] \cos(\omega_d t)\} x \\ &= -\{\omega_r^2 + V_\varepsilon [1 + V_m(\phi)]\} x \end{aligned} \quad (8)$$

where the parameter ε is now modulated by a sinusoidal signal at the same frequency. The behaviour of the controlled system depends on the strength m and the phase difference ϕ between the two signals $V_m(\phi)$ and V_ε .

The implementation of phase control is shown in the bottom part of the electronic scheme of Fig. 1, where two additional multipliers MLT04G have been included. The two function generators V_ε and $V_m(\phi)$ have been connected in a master-slave configuration ensuring a given and adjustable value of their phase difference.

Phase control has been applied to a stable solution near the border of instability region at $f_d = 1.77f_r$ (see Fig. 3).

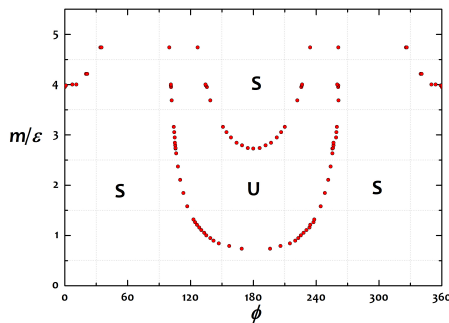

Figure 3. Stable (S) and Unstable (U) solutions. Phase control starting from a stable solution at $f_d = 1.77f_r$, $\varepsilon = 0.215$.

In this figure we can observe, in the region around $\phi = 180^\circ$, a transition from stable to unstable solu-

tions and vice versa as the perturbation strength m is increased.

4 Discussion

In this section we show the connection between entanglement and classical instabilities. By evaluating the logarithmic negativity, as defined in Ref. [Roque and Roversi, 2013], we observe the appearance of entanglement only for those values of m and ϕ where the classical oscillator is unstable (see Fig. 4). In the upper part of Fig. 4 we show the instability region associated with a positive Floquet coefficient λ_- . In the lower part of the same figure we report the logarithmic negativity E_N showing that entanglement only occurs when the classical dynamics is unstable.

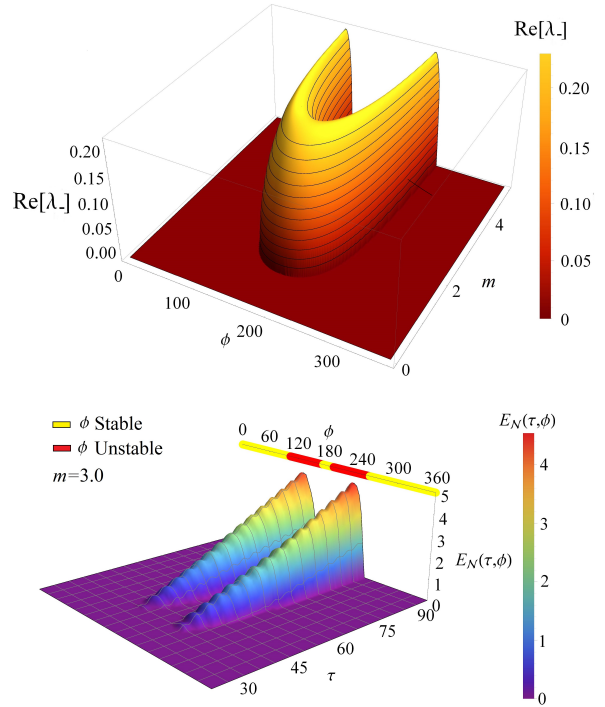

Figure 4. (Top) Map of Floquet exponent and (Bottom) Logarithmic Negativity E_N in term of phase and amplitude of perturbation.

5 Conclusion

The transition between stable and unstable solutions of a Mathieu oscillator has been investigated by means of the phase control technique. The appearance of instabilities is closely related to entangled states at high temperature of a system of two coupled oscillators interacting with a common heat bath. Thus, we can generate or suppress quantum entanglement controlling amplitude and phase of a external sinusoidal perturbation.

Acknowledgements

The authors wish thank Prof. F.T. Arecchi for helpful discussion and revision of the manuscript. This work was supported by Capes (Coordenação de Aperfeiçoamento de Pessoal de Nível Superior). We thank also the financial support by CNPq (Conselho Nacional de Desenvolvimento Científico e Tecnológico). This work also is linked with INCT-IQ (Instituto Nacional de Ciência e Tecnologia para Informação Quântica, FAPESP).

References

- Nielsen, M., Chuang, I. and Grover, L.(2002) Quantum computation and quantum information. *American Journal of Physics* **70**, pp. 558–560.
- Horodecki, R., Horodecki, P., Horodecki, M. and Horodecki, K.(2009) Quantum entanglement. *Rev. Mod. Phys* **81**, pp. 865–942.
- Galve,F., Pachón, L. A. and Zueco,D. (2010) Bringing entanglement to the high temperature limit. *Phys. Rev. Lett.* **105**, pp. 180501.
- Roque, T. F. and Roversi, J.A.(2013) Role of instabilities in the survival of quantum correlations. *Phys. Rev. A* **88**, pp. 032114.
- Gonzalez-Henao,J.C., Pugliese E., Euzzor S., Abdalah S.F., Meucci, R. and Roversi, J.A.(2015) Generation of entanglement in quantum parametric oscillators using phase control. Accepted for publication in *Nature Scientific Reports*.